

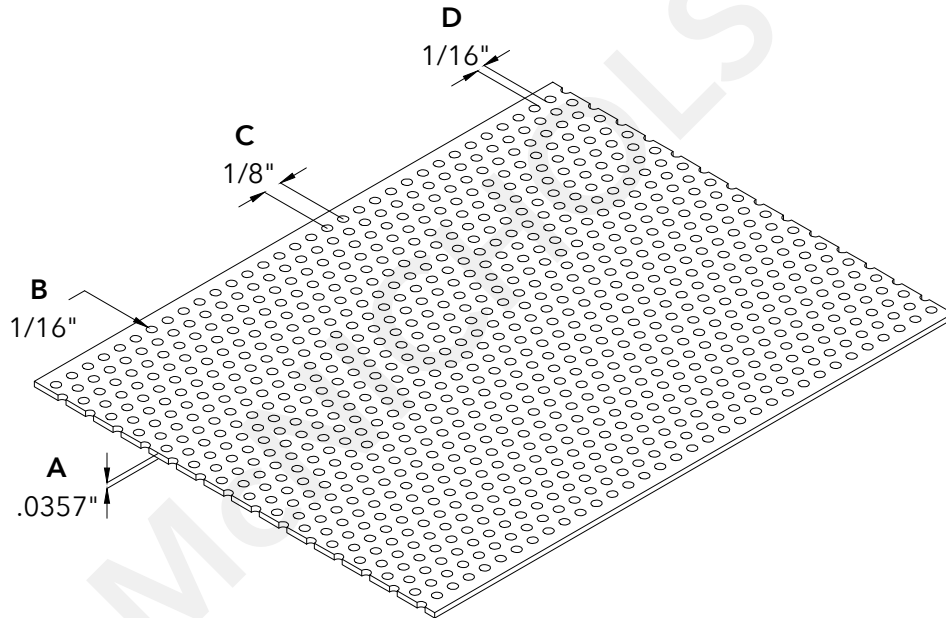

Top View

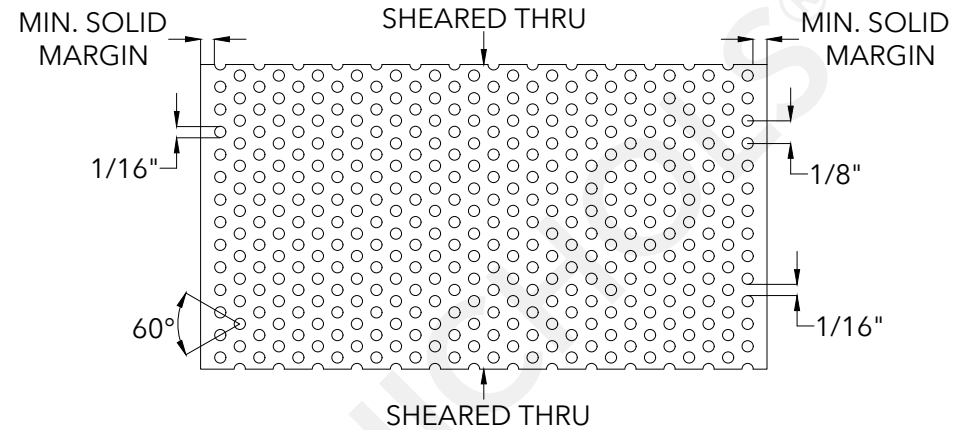

End View



800.237.3820
mcnichols.com

McNICHOLS® PERFORATED METAL

HOLE TYPE	Round
PRIMARY MATERIAL	Stainless Steel
HOLE PATTERN	1/16" Round on 1/8" Staggered Centers
HOLE ARRANGEMENT	60° Staggered Centers
PERCENT OPEN AREA	23%
A GAUGE/THICKNESS	20 Gauge (.0375" Thick)
B HOLE SIZE	1/16"
C HOLE CENTERS	1/8"
D BAR WIDTH	1/16"

DRAWING

NOT TO SCALE

Item Number 15111820
Revision Date 11.18.2025
Page Number 1 of 1

© 2025 McNICHOLS CO.
All Rights Reserved.

Drawing is for visual and conceptual purposes, is not to scale, and is based on nominal manufacturing data subject to standard production tolerances. McNICHOLS CO. does not provide engineering services of any kind. Technical information provided is for evaluation by technically skilled persons only, with any use thereof to be at their independent discretion and risk. McNICHOLS CO. shall have no responsibility or liability for results obtained or damages resulting from improper evaluation or use. McNICHOLS CO. makes no representation or warranty of any kind, express or implied, at law or in equity, regarding drawing including with respect to merchantability, fitness for any particular use or purpose, or design. All other representations or warranties are hereby disclaimed. This document and other related documents are subject to McNICHOLS CO. Terms and Conditions.