

**Top View**

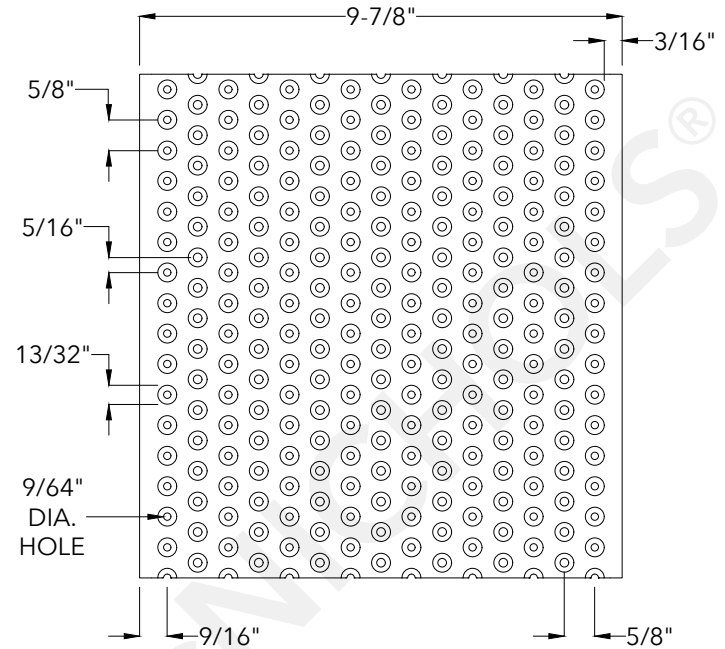

**End View**

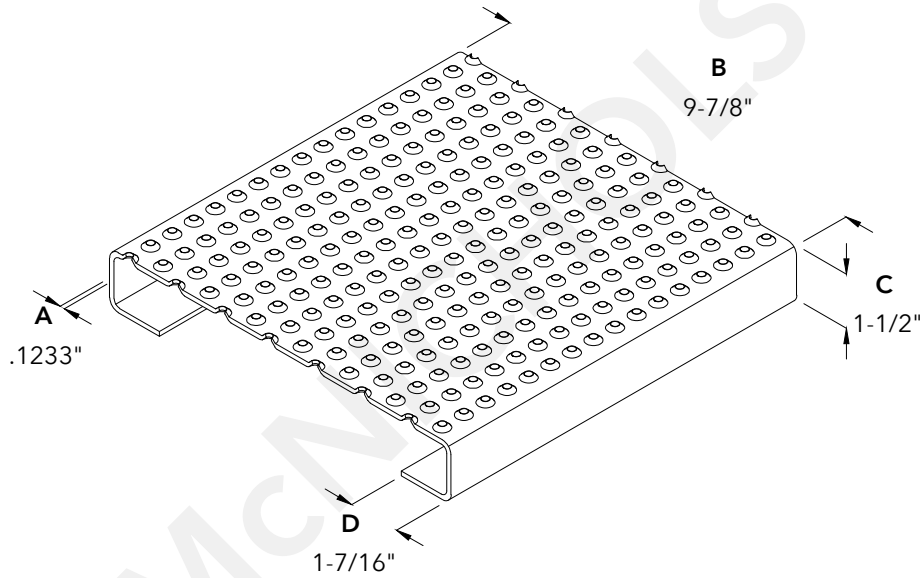
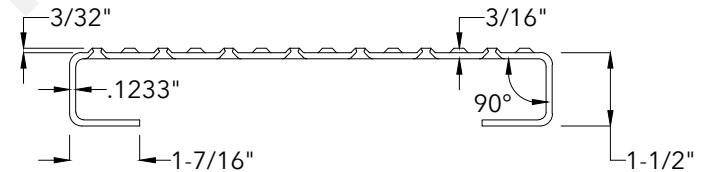

800.237.3820  
mcnichols.com

**McNICHOLS® PLANK GRATING**

**DRAWING**

Drawing is for visual and conceptual purposes, is not to scale, and is based on nominal manufacturing data subject to standard production tolerances. **McNICHOLS CO.** does not provide engineering services of any kind. Technical information provided is for evaluation by technically skilled persons only, with any use thereof to be at their independent discretion and risk. **McNICHOLS CO.** shall have no responsibility or liability for results obtained or damages resulting from improper evaluation or use. **McNICHOLS CO.** makes no representation or warranty of any kind, express or implied, at law or in equity, regarding drawing including with respect to merchantability, fitness for any particular use or purpose, or design. All other representations or warranties are hereby disclaimed. This document and other related documents are subject to **McNICHOLS CO.** Terms and Conditions.

CONSTRUCTION TYPE	Plank
SERIES NAME	TRACTION TREAD™
PRIMARY MATERIAL	Galvanized Steel
SURFACE PROFILE	Button-Top
PERCENT OPEN AREA	4%
<b>A</b> GAUGE/THICKNESS	11 Gauge (.1233" Thick)
<b>B</b> SURFACE WIDTH	10" (9-7/8" Actual)
<b>C</b> CHANNEL DEPTH	1-1/2"
<b>D</b> CHANNEL FLANGE WIDTH	1-7/16"

NOT TO SCALE

**Item Number** M2I01511  
**Revision Date** 12.09.2025  
**Page Number** 1 of 1

© 2025 **McNICHOLS CO.**  
All Rights Reserved.



ADA COMPLIANT WHEN INSTALLED USING MULTIPLE PIECES TO WIDTH REGARDLESS OF THE DIRECTION OF TRAVEL