

Top View

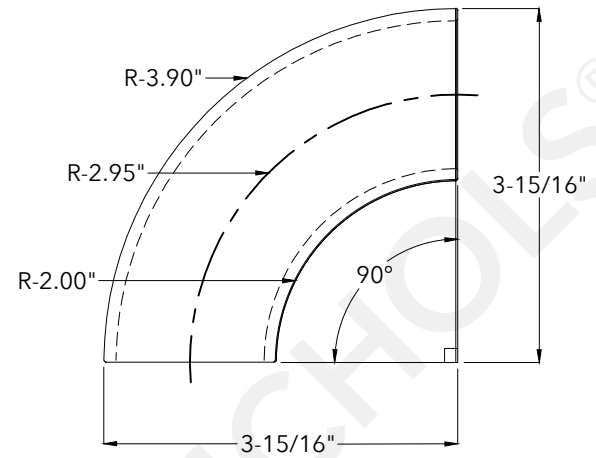

End View

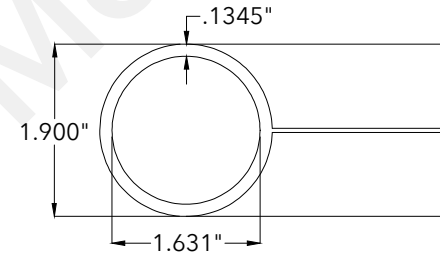

800.237.3820
mcnichols.com

McNICHOLS® HANDRAIL COMPONENTS

DRAWING

Drawing is for visual and conceptual purposes, is not to scale, and is based on nominal manufacturing data subject to standard production tolerances. **McNICHOLS CO.** does not provide engineering services of any kind. Technical information provided is for evaluation by technically skilled persons only, with any use thereof to be at their independent discretion and risk. **McNICHOLS CO.** shall have no responsibility or liability for results obtained or damages resulting from improper evaluation or use. **McNICHOLS CO.** makes no representation or warranty of any kind, express or implied, at law or in equity, regarding drawing including with respect to merchantability, fitness for any particular use or purpose, or design. All other representations or warranties are hereby disclaimed. This document and other related documents are subject to **McNICHOLS CO.** Terms and Conditions.

ATTACHMENT TYPE
COMPONENT TYPE
BEND TYPE
PRIMARY MATERIAL
COMPONENT PROFILE
COMPATIBLE WITH
WALL THICKNESS

Weld-On
Elbow
Radius
Carbon Steel
90° Radius Bend Elbow with Seam on Inside Radius
Fits 1-1/2" Round Pipe with a 1.900" Outside Diameter
10 Gauge (.1345" Thick)

NOT TO SCALE

Item Number WME535
Revision Date 08.09.2024
Page Number 1 of 1

© 2024 **McNICHOLS CO.**
All Rights Reserved.